

BAR SCREEN WITH AN INTEGRATED COMPACTOR

SPECIFICITIES

- > Installation : Pumping station / Channel
- > Secured interface screen / compactor
- > Bar spacing from 6 to 30 mm
- > Discharge height up to 6 m
- > Screenings discharge upstream
- > Rake driving by strap
- > Simple design, reliable and sturdy

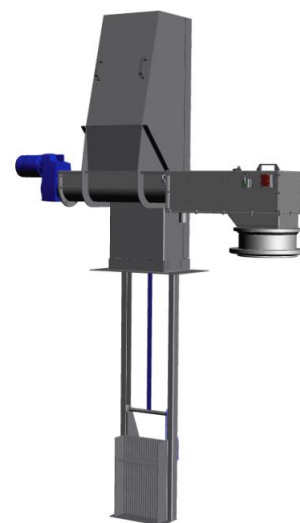

DESCRIPTION / OPERATION

STRAPSEP vertical screens, STR/P series, can be installed in channels or in pumping stations. They fulfill both fine or coarse screening function. They are equipped with a fully integrated ENVIROPRESS compactor for screenings dewatering.

The effluent passes through the screen, while the waste is stopped by vertical bars spaced apart according to the desired mesh.

The screen start-up is programmed periodically, and by loss of head measurement caused by the accumulation of waste on the bars. The waste is lifted by means of a rake going alternatively upward and downward. Driving of the rake is ensured by a strap.

○ FRAME

The structure of the screen is made up of two lateral frame structures offering two screening widths possibilities of 400 or 600 mm. For channel installation, lateral rubber bands are sealing the gap between screen and civil-work. For pumping stations, a quick-coupling flange is an integral part of the machine. It is possible to pull out the screen without going down to the bottom of the station.

○ FILTRATION SCREEN

The screen consists of fixed bars whose space between them defines the screening mesh. This simple technology is suitable for low flow rates, which can be used either as a fine or coarse screen (6 to 30 mm bar spacing).

○ MECANISM

The upward and downward movement of the rake is generated by the winding and unwinding of a strap. An innovative central guide mechanism directs the toothed rake between the bars for perfect penetration into the bars and an effective waste lifting.

○ COMPACTOR

The screening waste is falling down directly into an integrated screw compactor installed transversally where it is compressed and dewatered. Screenings can also be conditioned into a continuous plastic bagging unit before being dumped into a container.

TECHNICAL DATA

MATERIAL

- Construction in stainless steel 304L or 316L

PERFORMANCES

	Hydraulic flow rates with urban effluent (m ³ /h)					
Mesh (mm)	6	10	15	20	25	30
STR 500 P	73	91	104	112	117	121
STR 700 P	109	136	156	167	176	181

LAY-OUT AND DIMENSIONS

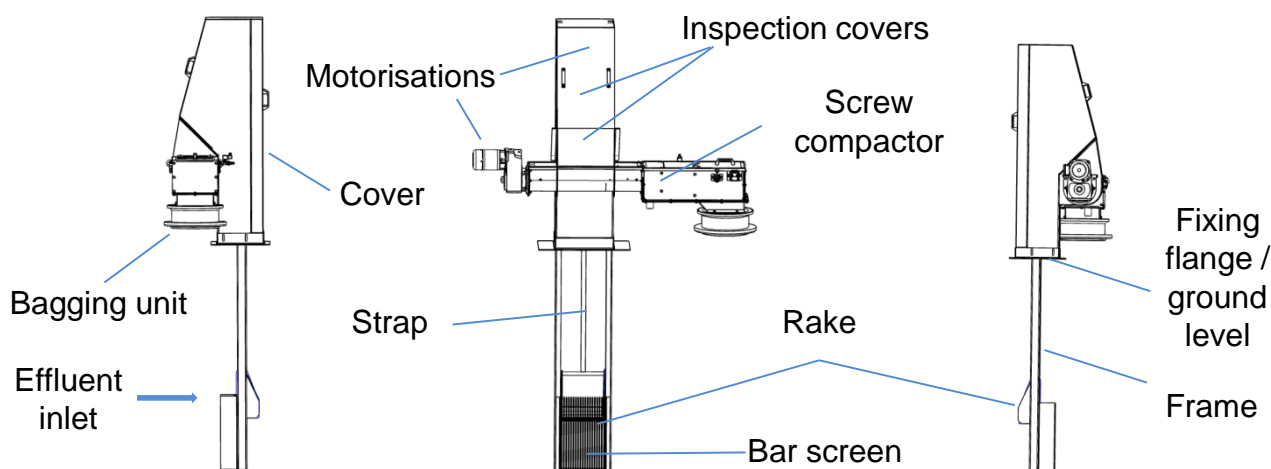

	Overall dimensions in mm					
Models	Discharge height maxi	Total height maxi	Channel width mini	Screen width	STR width with compactor	Channel hold length maxi
STR 500 P	6000	7100	500	400	2500	800
STR 700 P	6000	7100	700	600	2700	800

The ENVIROPRESS compactor can be replaced by a SPIRAPRESS compactor or by a simple ENVIROSPIR conveyor. It is also possible to combine several STRAPSEP Bar screens with the same compactor or with the same conveyor.

The manufacturer reserves the right to make technical and manufacturing modifications without prior notice. Not all installation possibilities and combinations are indicated. Please consult us.